

# Yanmar type 4BY180

## The Powerful Gem

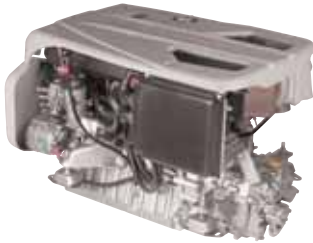

<b>Configuration</b>	In line, 4-stroke cycle, water cooled diesel engine
<b>Maximum output at crankshaft *</b>	132 kW ( 180 mhp) / 4000 rpm
<b>Continuous rating output at crankshaft</b>	102 kW (137 mhp) 3600 rpm
<b>Displacement</b>	1.995 L (122 cu in)
<b>Bore x stroke</b>	84 mm x 90 mm (3.31 in x 3.54 in)
<b>Cylinders</b>	4, Common Rail with vertical injectors
<b>Combustion system</b>	Direct injection
<b>Aspiration</b>	Wastegated, turbocharged with intercooler
<b>Starting system</b>	Electric starting 12 V - 2 kW
<b>Alternator</b>	12 V - 150 A
<b>Cooling system</b>	Fresh water cooling with heat exchanger, and sea water cooled charge air cooler
<b>Lubrication system</b>	Totally enclosed, forced lubricating system with pump
<b>Can Bus</b>	Device net according to NMEA 2000 protocol
<b>Direction of rotation (crankshaft)</b>	Counter clockwise viewed from stern
<b>Dry weight without gear</b>	250 kg (551 lbs)
<b>Environmental</b>	EPA Tier 2, RCD, SAV, BSO. Meets the EU comprehensive emissions regulation 2006
<b>Engine mounting</b>	Rubber type antivibration mounting

NOTE: Fuel condition: Density at 15°C = 0.84 g/cm<sup>3</sup>; 1kW = 1.3596 mhp = 1.3410 HP  
 \* Fuel temperature 40°C at the inlet of the fuel injection pump (ISO 8665)  
 Technical data is according to ISO 8665 / 3046

Dimensions (For detailed line-drawings, please refer to our web-site: [www.yanmarmarine.com](http://www.yanmarmarine.com))

### Front view

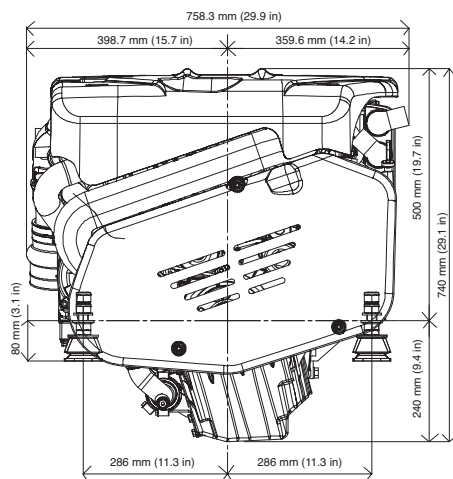

### Right side view

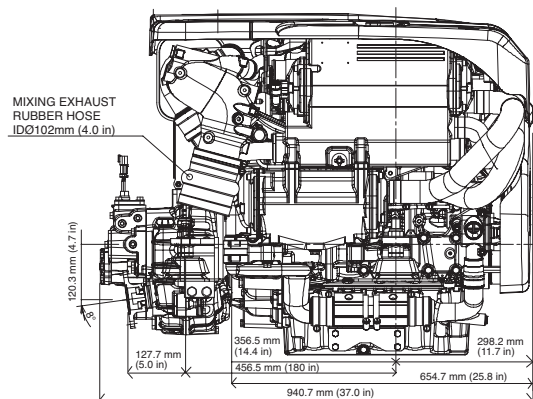

4BY180 w/ KMH40A marine gear

## Performance Curves (Output is according ISO 8665)

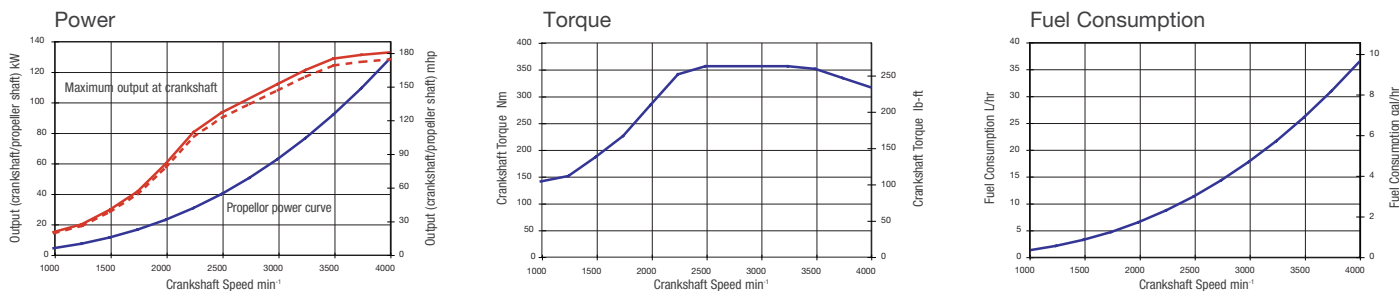

## Marine gear (examples) \*\*

Model	KMH40A				
Type	Mechanical multi-disc				
Dry weight	35 kg (77 lbs)				
Reduction ratio (fwd/asn)	1,24/1,24	1,53/1,53	2,04/2,04	2,45/2,45	2,62/2,62
Propeller speed (fwd/asn)	2903/2903	2353/2353	1765/1765	1469/1469	1374/1374
Direction of rotation (propeller shaft - fwd)	Clockwise & counter clockwise viewed from stern				
Dry weight engine and gear	285 kg (628 lbs)				
Length engine and gear	881mm (35 in)				

\*\* Other marine gearboxes and configurations available upon request. Contact your local supplier for more information.

## Instrument Panels

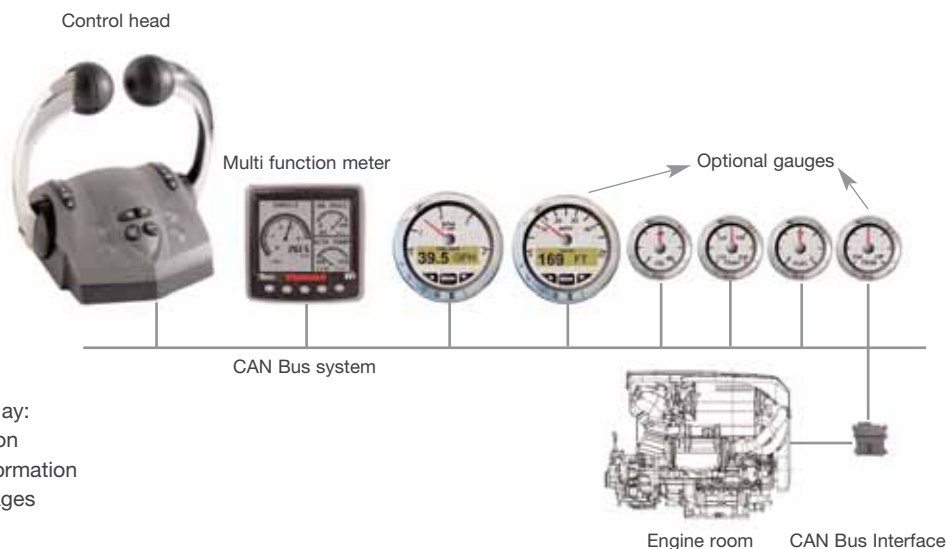

- Optional LCD panel display:
- engine information
  - maintenance information
  - diagnosis messages

## Accessories

### Standard Package

- Set of flexible mounts
- Alternator 12 V - 150 A single pole (24V is not available)
- Engine top and belt cover

- Exhaust mixing elbow (L-type)
- Single side mount control head (throttle position sensor included)
- CAN tachometer with digital display

### Optional

- High riser mixing elbow
- Exhaust side dipstick
- ECU boat mount kit
- Glow plug controller and related parts

- Dual top mount Teleflex control head (throttle position sensor included)
- Teleflex CAN single and double top mount control heads
- Teleflex interface module for analogue sensors (engine oil pressure, fuel tank level, etc)
- Various gauges

Texts and illustrations are not binding. Yanmar Marine reserves the right to introduce adaptations without prior notification.