

Yanmar type 6BY260

The Powerful Gem

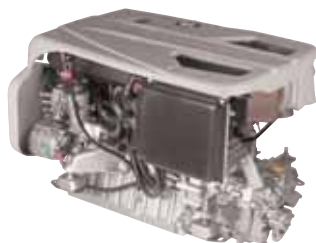

Configuration	In line, 4-stroke cycle, water cooled diesel engine
Maximum output at crankshaft *	191 kW (260 mhp) / 4000 rpm
Continuous rating output at crankshaft	147 kW (198 mhp) 3600 rpm
Displacement	2.993 L (183 cu in)
Bore x stroke	84 mm x 90 mm (3.31 in x 3.54 in)
Cylinders	6, Common Rail with vertical injectors
Combustion system	Direct injection
Aspiration	Wastegated, turbocharged with intercooler
Starting system	Electric starting 12 V - 2 kW
Alternator	12 V - 150 A
Cooling system	Fresh water cooling with heat exchanger, and sea water cooled charge air cooler
Lubrication system	Totally enclosed, forced lubricating system with pump
Can Bus	Device net according to NMEA 2000 protocol
Direction of rotation (crankshaft)	Counter clockwise viewed from stern
Dry weight without gear	310 kg (683 lbs)
Environmental	EPA Tier 2, RCD, SAV, BSO. Meets the EU comprehensive emissions regulation 2006
Engine mounting	Rubber type antivibration mounting

NOTE: Fuel condition: Density at 15°C = 0.84 g/cm³; 1kW = 1.3596 mhp = 1.3410 HP

* Fuel temperature 40°C at the inlet of the fuel injection pump (ISO 8665)

Technical data is according to ISO 8665 / 3046

Dimensions (For detailed line-drawings, please refer to our web-site: www.yanmarmarine.com)

Front view

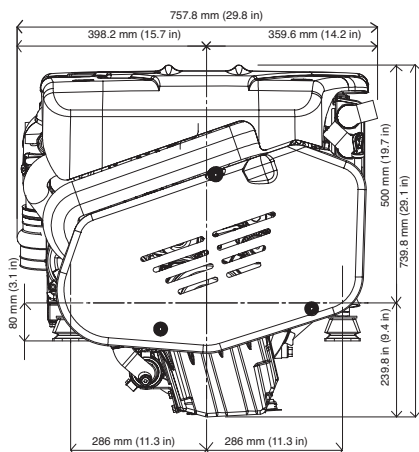

Right side view

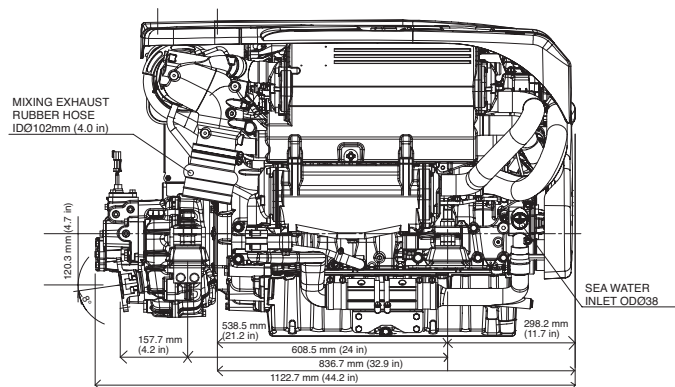

6BY260 w/ KM40A marine gear

Performance Curves (Output is according ISO 8665)

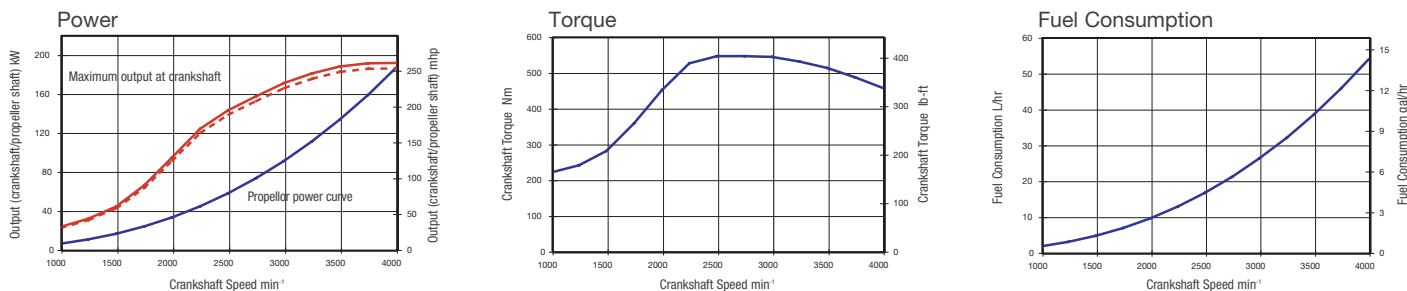

Marine gear (examples) **

Model	KMH40A			
Type	Mechanical multi-disc			
Dry weight	35 kg (77 lbs)			
Reduction ratio (fwd/asn)	1,24/1,24	1,53/1,53	2,04/2,04	2,45/2,45
Propeller speed (fwd/asn)	2903/2903	2353/2353	1765/1765	1469/1469
Direction of rotation (propeller shaft - fwd)	Clockwise & counter clockwise viewed from stern			
Dry weight engine and gear	245 kg (761 lbs)			
Length engine and gear	1053mm (41 in)			

** Other marine gearboxes and configurations available upon request. Contact your local supplier for more information.

Instrument Panels

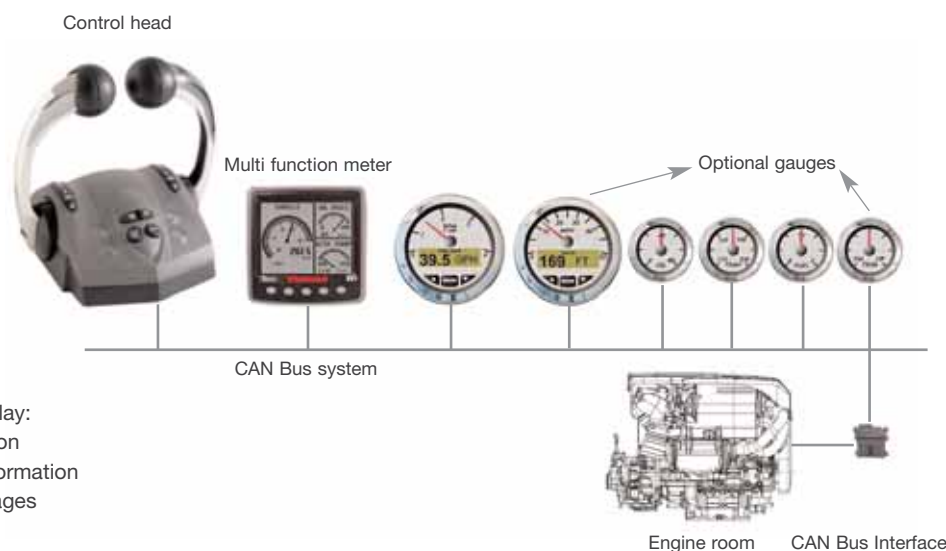

Optional LCD panel display:

- engine information
- maintenance information
- diagnosis messages

Accessories

Standard Package

- Set of flexible mounts
- Alternator 12 V - 150 A single pole (24V is not available)
- Engine top and belt cover

- Exhaust mixing elbow (L-type)
- Single side mount control head (throttle position sensor included)
- CAN tachometer with digital display

Optional

- High riser mixing elbow
- Exhaust side dipstick
- ECU boat mount kit
- Glow plug controller and related parts

- Dual top mount Teleflex control head (throttle position sensor included)
- Teleflex CAN single and double top mount control heads
- Teleflex interface module for analogue sensors (engine oil pressure, fuel tank level, etc)
- Various gauges

Texts and illustrations are not binding. Yanmar Marine reserves the right to introduce adaptations without prior notification.