

Tier 2 Commercial / Certification

6LY3-STC Series

Configuration	24 valve, 4-stroke, vertical, water cooled diesel engine
Maximum output at crankshaft	* 316 kW (430 mhp) / 3300 rpm
Continuous rating output at crankshaft	295 kW (400 mhp) / 3198 rpm
Displacement	5.813 L (354 cu in)
Bore x stroke	106 mm x 110 mm (4.17 in x 4.33 in)
Cylinders	6 in line, 24 Valve
Combustion system	Direct injection
Aspiration	Turbocharged with seawater cooled intercooler
Starting system	Electrical starting 12V - 3kW
Alternator	12V - 80A
Cooling system	Fresh water cooling by centrifugal fresh water pump and rubber impeller seawater pump
Lubrication system	Enclosed, forced lubricating system
Direction of rotation (crankshaft)	Counter clockwise viewed from flywheel side
Dry weight without gear	640 kg (1411 lbs)
Environmental	EU RCD, US EPA Tier2 (commercial), EMC, EPA/IMO, IMO Tier2
Engine mounting	Rubber type flexible mounts

NOTE: Fuel condition: Density at 15°C (59 F) = 0.84 g/cm³; 1kW = 1.3596 mhp = 1.3410 HP

* Fuel temperature 40°C at the inlet of the fuel injection pump (ISO 8665)

Technical data is according to ISO 8665

Dimensions (For detailed line-drawings, please refer to our web-site: www.yanmarmarine.com or contact your supplier)

Front view

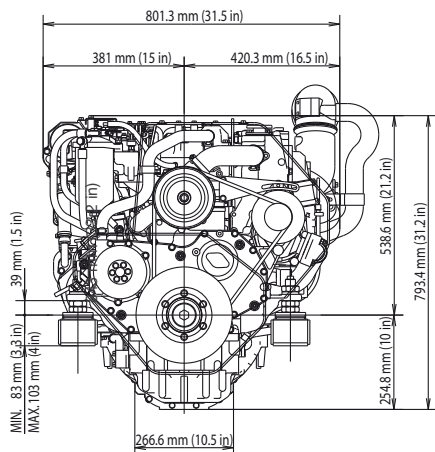

Right side view

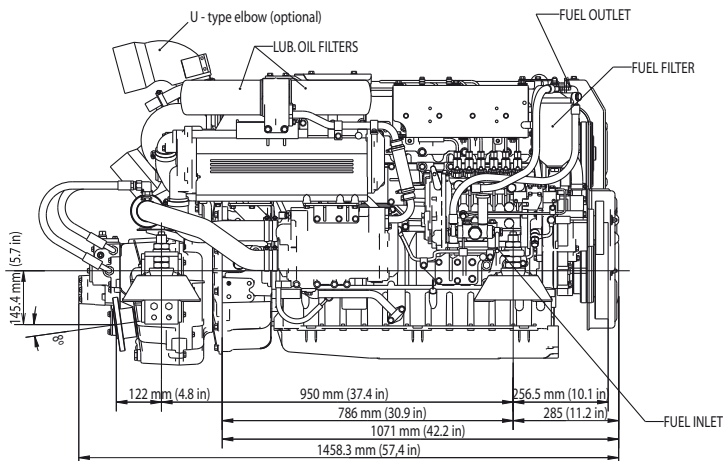

Performance Curves (Output is according ISO 8665)

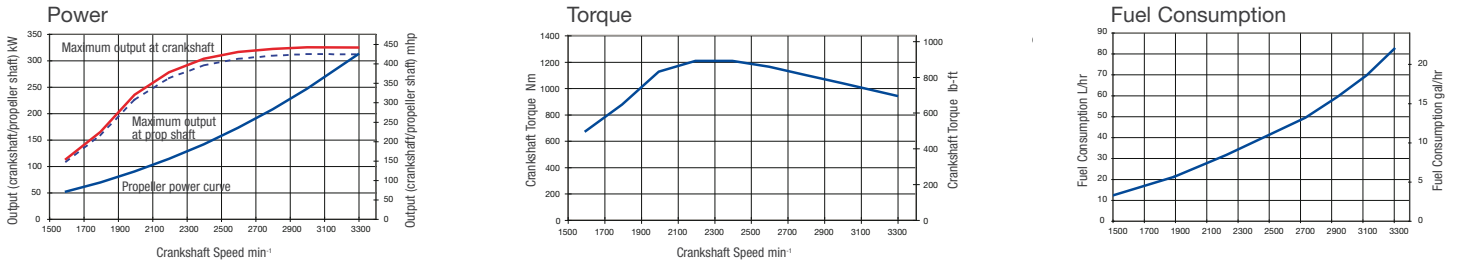

Marine gear (example) **

Model	KMH61A			ZF85A		
Type	Hydraulically actuated multi-disc clutch			Hydraulically actuated multi-disc clutch		
Dry weight	78 kg (172 lbs)			90 kg (198 lbs)		
Reduction ratio (fwd/asn)	1.55/1.55	2.04/2.04	2.43/2.43	1.57/1.57	1.96/1.96	2.50/2.50
Propeller speed (fwd/asn)	2129/2129	1618/1618	1358/1358	2102/2102	1684/1684	1320/1320
Direction of rotation (propeller shaft - fwd)	Clockwise & counter clockwise viewed from flywheel side			Clockwise & counter clockwise viewed from flywheel side		
Dry weight engine with gear	718 kg (1583 lbs)			730 kg (1609 lbs)		
Length engine with gear	1357 mm (53 in)			1373 mm (54 in)		

** Other marine gearboxes and configurations available upon request. Contact your local supplier for more information.

Instrument Panels

Various Control heads



Multi function LCD display



CAN Bus system

Multi function LCD display:

- engine information
- maintenance information
- diagnosis messages



Engine ECU Interface

Engine Accessories

Standard Engine Package

- Standard Engine Package
- Air heater
- Belt Cover

Optional Engine Package

- Fuel/Water separator
- High riser mixing elbow, L-Type or U-Type
- Lub oil evacuation pump
- 24 Volt Alternator
- Flexible mounts

Electronic Control System

Standard Electronic Control System (purchased separately)

- CANBUS-NMEA 2000 electronic control system
- Ignition panel with rocker switches
- Multi-function LCD display
- Electronic control head

Optional Electronic Control system

- Second station kit for Flybridge
- Ignition panel with Keyswitch
- Extension wire harnesses
- Various control heads
- Trolling mode kit